

DEHUMIDIFIER INSTRUCTION MANUAL

MODEL: CD-25L

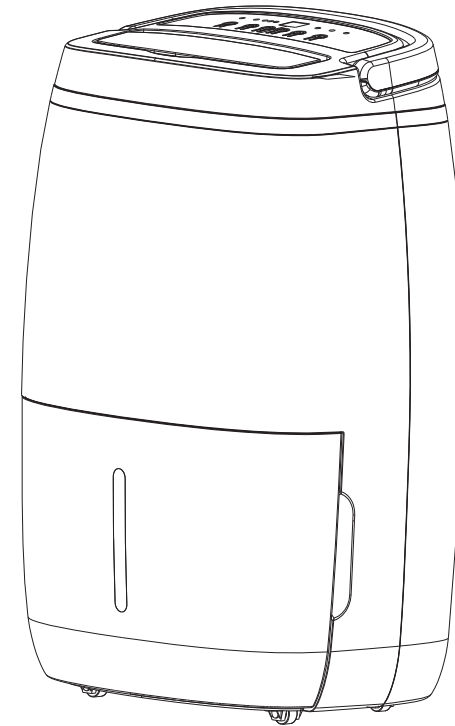

**Thank you for choosing this product.
Please read this instruction manual before using it.**

Trouble codes:

Please contact local distributor if any of the trouble codes below appears.

Displayed Code	E1	E2
Error	Coil temperature error	Humidity Sensor is broken
Display	Flash every 30s	Flash every 30s
Explain	Normal operating of the unit will not be influenced, but unit starts working in defrosting mode.	Actual humidity will be permanent displayed in 50%RH; unit will become in continuous operating mode, capable for further use.

CONTENS

Product introduction.....	1
Warning and Cautions.....	1-2
Parts List.....	3
Operation Panel.....	3
LED Indicator.....	4
Prior to Operation.....	5-6
Operation Instructions.....	7
Care and Maintenance.....	8-9
Trouble Shooting Tips.....	10
Trouble codes.....	11

Product introduction

The unit can remove moisture from the air by compressor dehumidifying, so it can help to keep carpets, floors, walls, and other articles in the building dry, and it also can be used in file rooms, underground projects, commodity storage, medicine and health care where need a dry environment, the dehumidifier can prevent them from damp and mildew.

Warning and Cautions



To prevent from injury to the user or other people and property damage, the following instructions must be strictly obeyed.



Be sure to follow the instructions.



Do not use wet hands.



Be sure not to do.

Trouble Shooting Tips

Please try the suggestions below to see whether you can solve the problem without outside help.

PROBLEM	POSSIBLE CAUSE	SOLUTION
Unit does not operate	Unit power cord is unplugged.	Pull the plug and connect it again or please check if there are power in the outlet.
	Unit has not been turned on.	Turn on the switch.
	Light of water full is flashing.	Water tank is full, empty the tank; make sure the tank is in the right place; the float flops, relocate it.
Dehumidifying capacity(water removal) is low	Runtime is too short.	Waiting.
	Air filter is dirty and/ or obstructed.	Use water to clean the filter.
	Ambient room temperature is too low or humidity too low.	Dehumidifying capacity is normally lower if the room temperature is below 18°C. please try to increase the room temperature.
	Setting humidity is higher than the ambient humidity	Setting the humidity down and lower than the ambient humidity
Relative Humidity setting not reached after long period of operation.	Drainage water pipe is blocked or flat.	Check the water pipe and replace it if necessary.
	Doors and windows are not closed or sealing capacity of ambient room is not good.	Close the door and windows or enclose the space.
Water on floor	Unit is lurches too much by moving; residual water in unit.	Normal phenomenon
Outlet air is warm.	Heat exchanging processes.	Normal phenomenon
Water noise	Refrigerating fluid flows.	Normal phenomenon

Care and Maintenance

- D. Don't use the unit near heat producer like stove, heater or cold air influence dehumidifying effect or cause danger.
- E. Don't put the unit at the place where it may be splashed lest it causes electrical leaks.
- F. Unit should be safely placed before operated, make sure it will not upset and cause danger.
- G. Pay attention to the room humidity level if the room is decorated with wooden furniture or other woodwork, for exceeding dryness will result wood cracking.
- H. Serious pitch and pump, excessive slope will cause operation problems, e.g. operating noise will become higher. Residual water in unit may also run over under the excessive slope.

Cautions

This unit must be reliably grounded or plugged into a grounded outlet.

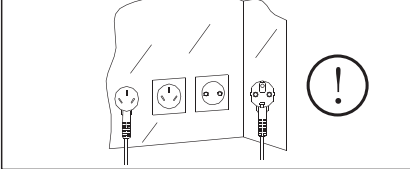

If the supply cord is damaged, it must be replaced by the manufacturer, its service agent or similarly qualified persons in order to avoid a hazard.



This unit use special electrical connection and outlet, don't use other extension wire or portable outlet.

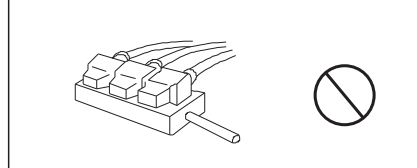

This unit should be turned on/off in right way, repeated plugging the connector is certainly a wrong way, please don't do this. If the unit will be left unused for a long time, pull out the plug.

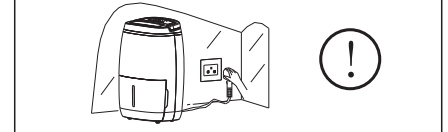

This appliance is not intended for use by persons (including children) with reduced physical, sensory or mental capabilities, or lack of experience and knowledge, unless they have been given supervision or instruction concerning use of the appliance by a person responsible for their safety.



Do not touch the power switch or outlet with wet hands, it may cause electric shock.

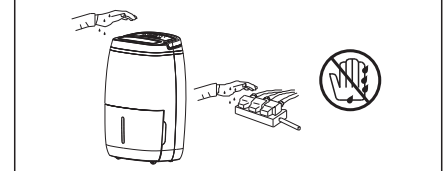

Children should be supervised to ensure that they do not play with the appliance.



Do not put your hands or other sticks in the air outlet, it's dangerous.



Warm air coming from the unit may harm the health of people and animals so don't stay before the air outlet for too long time.



Do not operate this unit near corrosive, flammable, explosive materials.

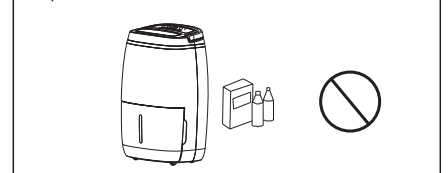

Parts List

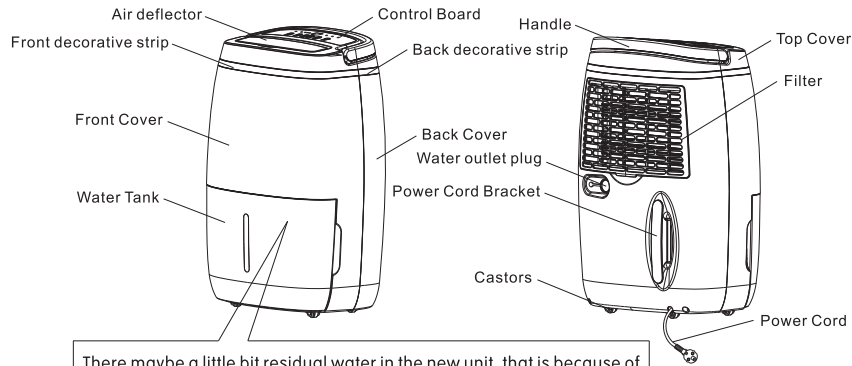

There may be a little bit residual water in the new unit, that is because of performance test before selling, not malfunction or disqualification.

Operation Panel

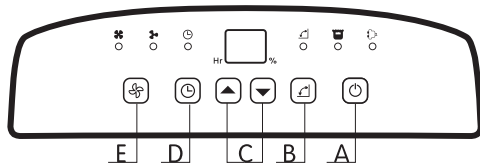

- A. “” ON/OFF: Press once to turn the unit ON or OFF.
- B. “” key: used to air deflector to automatically change its direction.
- C. “” up and “” down
 - a. used to set the target humidity, the value will rise or drop 5% by each pressing down.
 - b. used to set the target shutdown time, the value will rise or drop 1 hour by each pressing down.
- Note: If there are no pressing up or down in 5s, the value will be kept.**
- D. “” key: used to set the timing shutdown.
- E. “” key: used to change the fan speed between high one and low one.

Note: Lock key program is designed for this unit, pressing “” and “” at the same time for 2 seconds, all keys on panel will be locked. To release the lock you just need repeat the previous operation again.

Care and Maintenance

Note: Caution: To avoid unexpected accident, unit must be disconnected from power supply before maintenance.

A. Clean the Air Filter

Air filter gathers dust and is easily be obstructed, to achieve the best operating efficiency, regular clean is necessary.

Clean the filter every 1 to 5 days if ambient space is dusty.

Clean the filter every month if ambient space is reasonably clean.

How to clean air filter:

- a. pull out the air filter(as following illustration).
- b. suck the dust on the surface of air filter with vacuum, or wash it with warm water(not high than 40°C)
- c. make the filter dry(by airing or shake it), install it in machine.

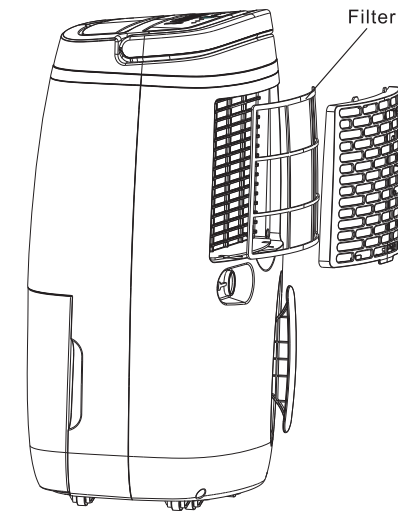







Filter should not be baked by fire or under the sun for many times.

B. Check the Drainage Water Pipe :

It is necessary to keep the water pipe unobstructed to drain the water smoothly and make the unit work normally. You should check the water pipe regularly and replace it if necessary.

C. Pull the plug from power supply and water tank should be empty after using.

Operation Instructions

- A. “” On/Off
- Turn the air deflector to its side and adjust it to proper position.
 - Press “ON/OFF” key once while unit is energized, unit begins to work.
 - Press “ON/OFF” once again after use, unit will shut down; turn back the air deflector.
- Note: Let the unit rest for about 3 minutes after turned off, so that residual water on condenser can flow into the tank. Pull out the plug when the unit is off for power saving and safety.**
- B. “” Wind
- As soon as the unit is turned on, air deflector will move to the position at a angle of 90°. If the key is pressed once, air deflector will keep waving between 45° and 90°, and the indicating light will be on; if the key is pressed again, air deflector will stop moving at once, and the indicating light goes off. When the unit is turned down, air deflector will close automatically.
- C. “” Up and “” Down
- Humidity Setting (in dehumidifying working mode)
Humidity can be set by pressing keys “UP” and “DOWN” within a range of 30% to 80% RH.
After start-up, the original value is “CO”, press “UP” and “DOWN” to change the value as you want. Waiting for 5S, the unit accepts the order and then the actual humidity value appear on the panel. If the humidity has been set under 30% RH, “CO” appears on the panel and the unit will operate continuously.
 - Setting timing shutdown. (In dehumidifying working mode)
Please refer to the following instruction about the “Timer”.
- D. “” Timer
- Under running condition, the indicator of “TIMER” begins to flash when the key has been pressed, simultaneously the setting-up time will appear on the digital screen. Original value is 00, i.e. timing shutdown setting is off. By pressing keys “UP” and “DOWN” in 5S the setting-up time can be expended or shortened, then waiting for another 5S, if the indicator of “TIMER” is always on, Timing shutdown setting succeeds. Actual humidity in the room will subsequently appear on the panel. E.g. with the value setting of “06”, the unit will shut down automatically after 6 hours.
- E. “” Fan
- Under running condition, press the key to change fan speed between high one and low one.
- F. Cautions of moving the Water Tank
- Only when the unit is off can water tank be drawn out, keep the tank steady during moving it.
 - Support the tank base during moving before pouring.
 - Be careful not to move or damage the float.

LED Indicator

“” Operating Indicator :

When the unit is energized, it goes into standby mode, and the indicator flashes. When tuning on, this indicator is always on. When turning off, the unit goes into standby again, the indicator flashes as beginning. During defrosting, the light will be flashing, and after defrosting, the light will be on.

“” Water tank full indicator:

When the water tank is full, unit will go into standby mode, and the indicator begins to flash in high frequency. When it is resolved, the indicator will don't flash any more, the unit will go on to the original mode.

“” Air deflector light:

It will go on if air deflector is automatically changing its direction.

“” Timing shutdown indicator:

It will begin to flash when the timing shutdown key was pressed; will be always on after the setting takes effect; It will go out when the settled time is up or the timing Shutdown setting was canceled.

“” “” Fan speed indicator:

They respectively indicate high wind or low wind.

Prior to Operation

- A. Put the unit in proper location: complying with the requirements below can help the unit achieve its best performance.

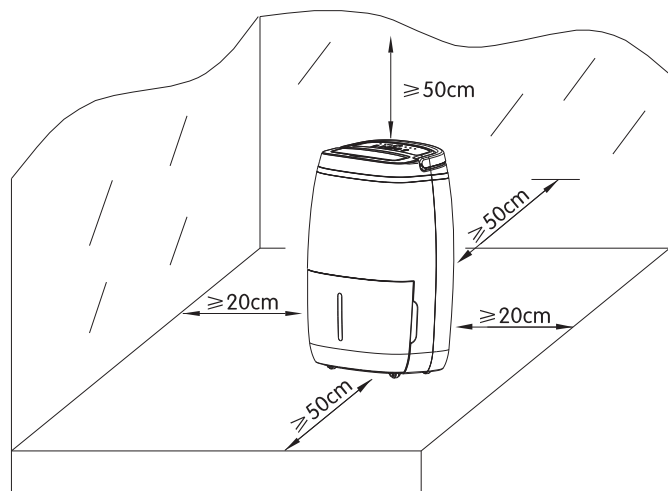

- B. Supply power should be in correspondence with the value on the nameplate.
Power outlet need be grounded.
- C. Take the main cord and plug it properly.
- D. Check and make sure that the space before air in/outlet is clear. Free wind flow is the key to optimum performance and energy conservation.
- E. Push down air deflector before turning on the unit.
- F. If continues dehumidifying function need to be used for a long period, drainage pipe will be useful. Below are detailed operating procedures:
- Open the revolving door for hose connector and take the plug off (see Figure1)
 - Plug drainage pipe with 12mm in diameter in the hose connector and tie it tense in case of leaking (see Figure 2).

Prior to Operation

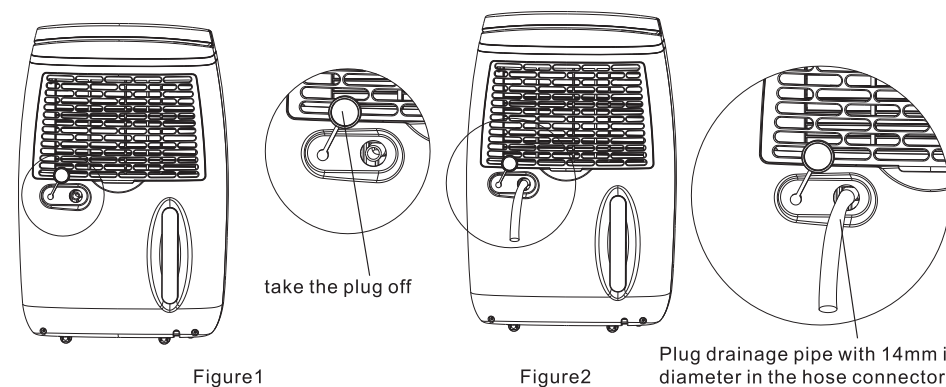

Note: Smoothly stretch the drainage, for if it is flat or twists together, drainage will not go on right; even the unit can not work normal. During the operation drainage pipe should never be in higher position than the hose connector.